



[www.sdgspa.it](http://www.sdgspa.it)

**Customer:** Standard

**Code:** 160

**Product:** Cup 160 - Content: 230ml To lid 165 ml

**Board Composition:** 100% virgin fiber with

Polyethylene coating 230+15PE g/mq

**Printing type:** OFFSET

**Product Weight:** 7 g

## IMAGE AND TECHNICAL DRAW /

The size are in mm.

**ON DEMAND:**

we realize lodging for the paper Lid Ø 84,4 mm

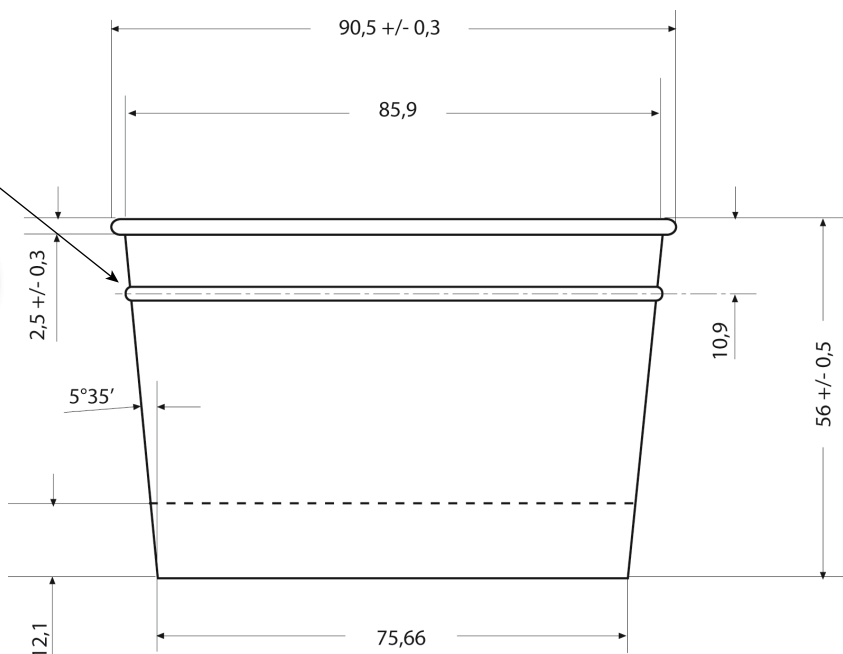

## PACKAGING PRODUCT /

**Box Type:** Waved carton box Havana brown

**External Box size (W x L x H):** 600 x 400 x 585h mm

**Gross weight:** 10,5 kg

**Net weight :** 9 kg

**Unit / Pack:** 43

**Packs / Box:** 30

**Unit / Box:** 1.290

**Packs Type:** Polyethylene packs

**Label per pack:** Yes

**Label per box:** Yes

**Box / Pallet:** 16

**Box per layer:** 4      **Layers per pallet:** 4

**Size pallet:** 80 x 120 losing

**Pallet hight:** about 2,5 m (with pallet)

Il presente articolo è disponibile nelle seguenti grafiche:

<b>BIANCA</b> .....	Code 160-00 EAN code 8032532913963
<b>BIMBI MARE</b> .....	Code 160-11 EAN code 8032532913130
<b>LATTE FRUTTA AZZURRA</b> .....	Code 160-12 EAN code 8032532910993
<b>TEXT</b> .....	Code 160-22 EAN code 8032532917862
<b>TUTTI FRUTTI</b> .....	Code 160-10 EAN code 8032532913116
<b>VINTAGE VERDE</b> .....	Code 160-17 EAN code 8032532913109
<b>BUBBLES GIALLA</b> .....	Code 160-25 EAN code 8032532919095

## TECHNICAL SPECIFICATIONS:

Property / unit	Standard	
<b>Coated board:</b>		
Grammage, g/m <sup>2</sup>	245	ISO536
PE, g/m <sup>2</sup>	15	Mill Method
Thickness, µm	333	ISO 534
<b>Baseboard:</b>		
Bending resistance L&W 15°MD, mN	215	ISO2493-1
Bending resistance L&W 15°CD, mN	95	ISO2493-1
Stretch CD, %	6.0	ISO1924-3

The cardboard used and the product are FSC® certified

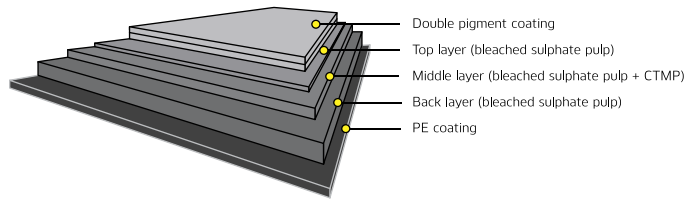

The raw materials used for the manufacture of the product are of European origin.

Inks and varnishes are low odor and low migration suitable for printing of primary packaging produced in accordance with the **EUPIA** guidelines.

## CONFORMITY AND WAY OF EMPLOYMENT: /

According to internal tests regarding the technological suitability, SDG declares that the product can be used in the following ways:

The artifact may be used, together with the food, in a traditional oven SI NO  
If Yes, indicate time and maximum temperature \_\_\_\_\_

The artifact may be used, together with the food, in a microwave oven SI NO  
If Yes, indicate time and maximum power \_\_\_\_\_

The artifact may be used, together with the food, at low temperatures SI NO  
If Yes, indicate time and minimum temperature (-18°C per 24 months)

**It is recommended to verify technological suitability in the final real application according to the timing and temperatures of use.**

This product is food contact suitable according to the CE n° 1935/2004 regulation, CE 10/2011 regulation and following updates and to the D.M. of the 21<sup>st</sup> march 1973.

This product is disposable, it is recommended to use within 3 years from the manufacturing date.

It must be stored in a dry place, faraway from sun rays and heat sources (0°C +35°C).

Acceptable quality level (**AQL**): 1% of the lot delivered

**THIS PRODUCT IS NOT A TOY.**